

# FAWNS cycle shelters

## THE COMPLETE MODULAR SYSTEM

# The Midway Shelter

c/w Roof & Gate each end

CODE: CYMID01

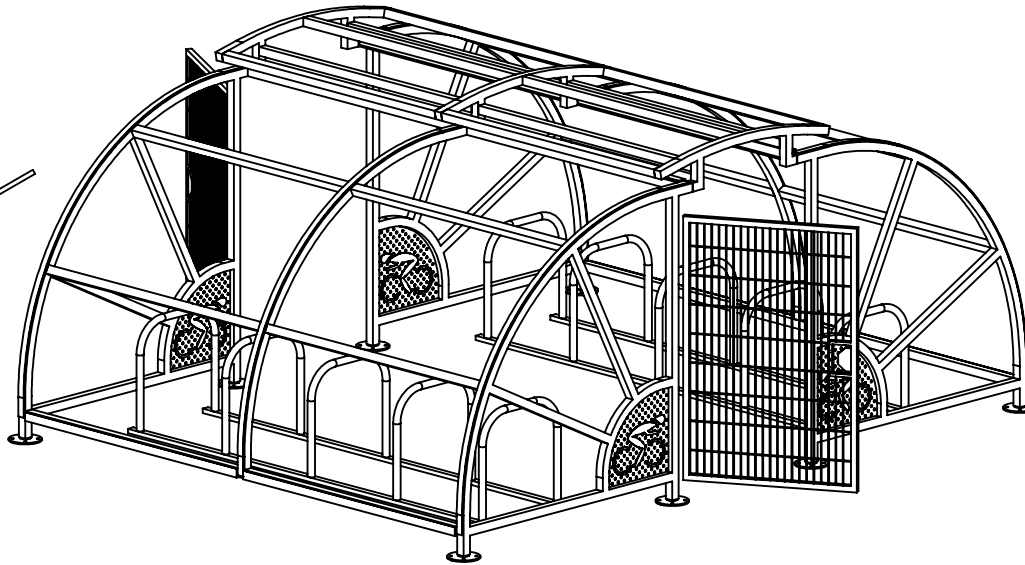
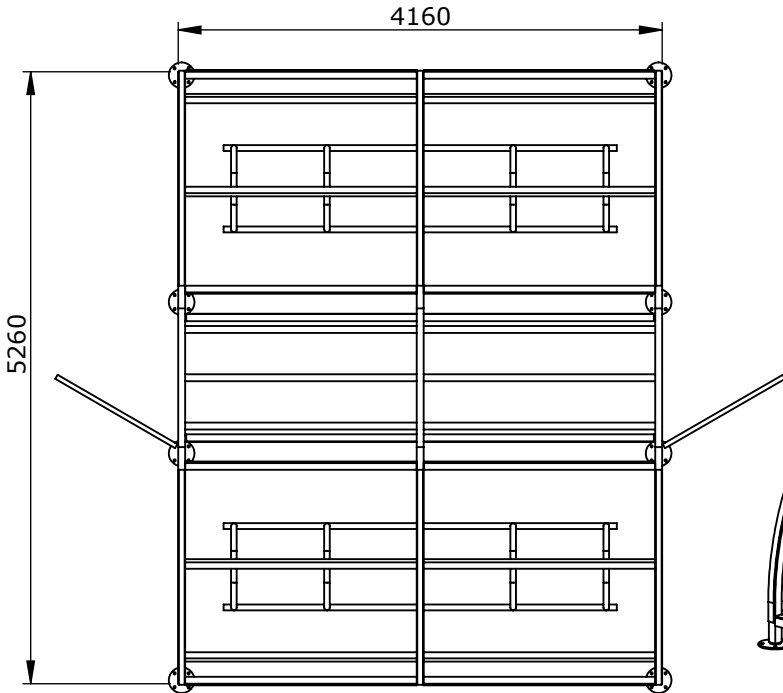
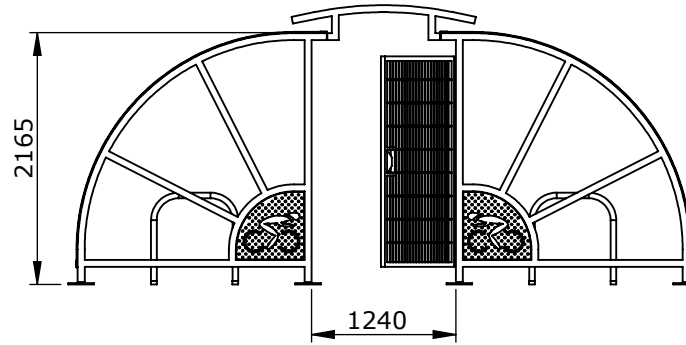
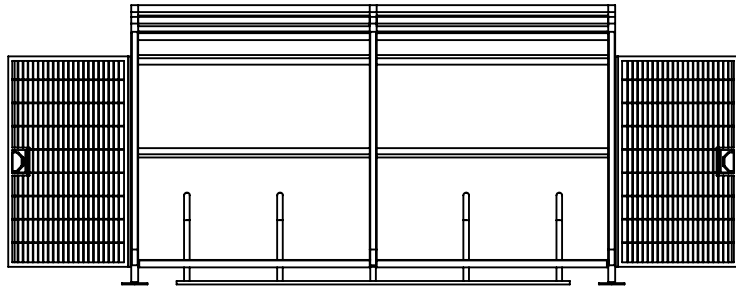

### Standard Specifications

- HEAVY DUTY STEEL FRAME
- UNIQUE HUB DESIGN
- STAINLESS STEEL FIXINGS TO ALL STRUCTURAL JOINTS
- ADJUSTABLE FEET
- 5mm UV PETG CLADDING
- GALVANISED TO BS EN ISO 1461

### Options available

- POWDER COATED TO A CHOICE OF COLOURS
- SENIOR & JUNIOR RACKS AVAILABLE; ROOT, BASEPLATE OR TOAST RACK FIXING
- INCORPORATE OWN DESIGN INTO HUB
- SLIDING GATES AVAILABLE (CAN BE FITTED AFTER)
- CAN BE ROOT FIXED (EXTRA FITTINGS REQUIRED)
- END UV PETG PANELS CAN BE ENGRAVED WITH YOUR LOGO
- CAN BE EXTENDED AFTER INSTALLATION TO FORM A COMPOUND OR INLINE SHELTER

DIMENSIONS:- 4160L X 2165H X 5260W

CAPACITY :- 20 CYCLES WHEN USING DOUBLE SIDED STANDS

NOTE:  
UV PETG PANELS ARE NOT SHOWN

Fawns Recreational Services Ltd, Woodcot Court, Woodcot Gardens, Farnborough, Hampshire GU14 9RD  
 Tel: 01252 515 199 / Fax: 01252 515858 / Email: fawns@fawns.co.uk / <http://www.fawns.co.uk>  
 (C) Fawns 2009 - Not to be reproduced by any means or in any form without the written permission of Fawns Recreational services Ltd



DRAWING No. CYMID01