

CODE: CYCRES01

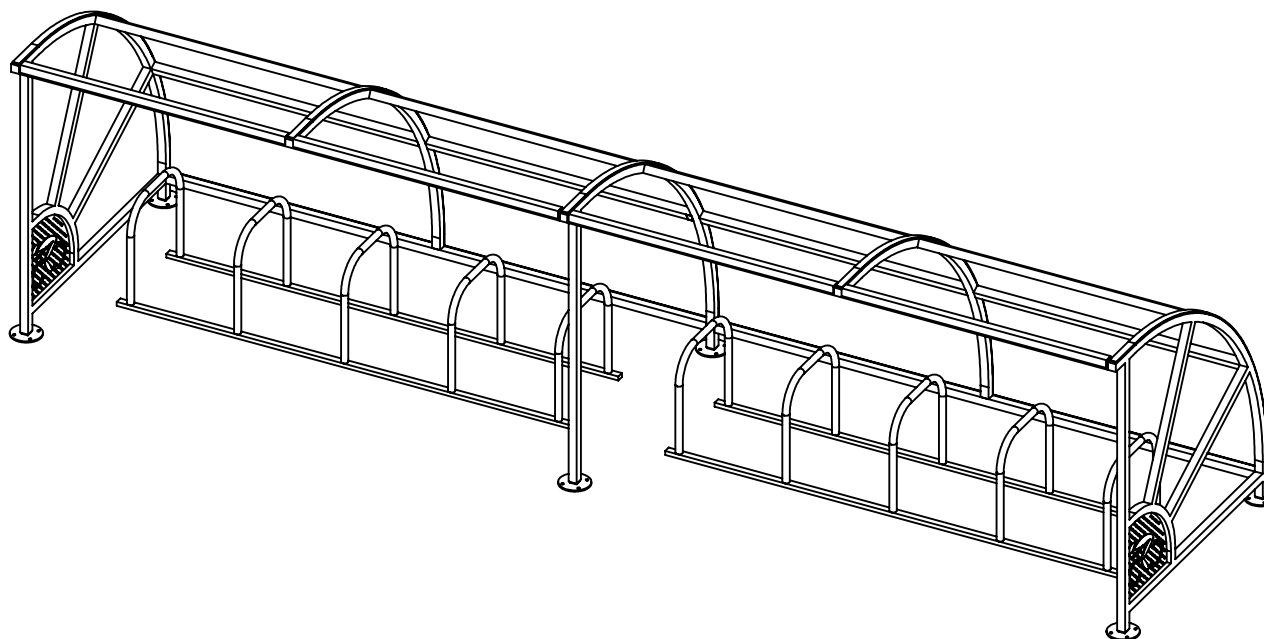
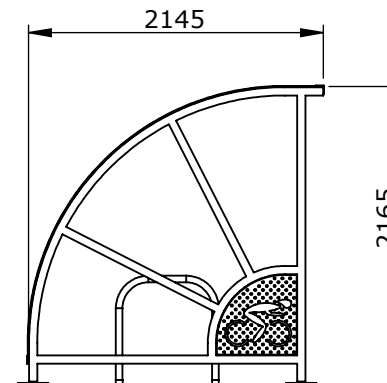
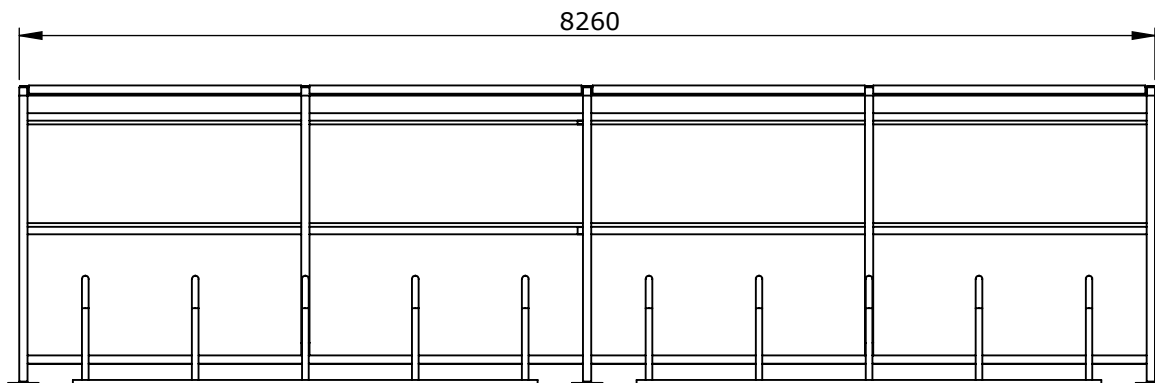

Standard Specifications

- HEAVY DUTY STEEL FRAME
- UNIQUE HUB DESIGN
- STAINLESS STEEL FIXINGS TO ALL STRUCTURAL JOINTS
- ADJUSTABLE FEET
- 5mm UV PETG CLADDING
- GALVANISED TO BS EN ISO 1461

Options available

- POWDER COATED TO A CHOICE OF COLOURS
- SENIOR & JUNIOR RACKS AVAILABLE; ROOT, BASEPLATE OR TOAST RACK FIXING
- INCORPORATE OWN DESIGN INTO HUB
- SLIDING GATES AVAILABLE (CAN BE FITTED AFTER)
- CAN BE ROOT FIXED (EXTRA FITTINGS REQUIRED)
- END UV PETG PANELS CAN BE ENGRAVED WITH YOUR LOGO
- CAN BE EXTENDED AFTER INSTALLATION TO FORM A COMPOUND OR INLINE SHELTER

DIMENSIONS:- 8260L X 2165H X 2140W

CAPACITY :- 20 CYCLES WHEN USING DOUBLE SIDED STANDS

NOTE:
 UV PETG PANELS ARE NOT SHOWN